

2022 LIGHTNING RODS SPECIFICATIONS, RULES AND REGULATIONS



CONTENTS

1.	CARS	1
2.	ENGINE	1
3.	EXHAUST SYSTEM	2
4.	CARBURETTOR & INLET MANIFOLD	2
5.	GEARBOX & DIFFERENTIALS	2
6.	FRONT SUSPENSION	3
7.	REAR SUSPENSION	3
8.	STEERING	3
9.	WHEELS & TYRES	3
10.	BRAKES	3
11.	BODYWORK	3
12.	ROLL CAGES	3
13.	SCREEN	5
14.	STOP LIGHTS	5
15.	SEATS	5
16.	BATTERIES & ELECTRICAL	5
17.	NUMBERS	5
18.	FUEL SYSTEM	6
19.	FUEL	6
20.	ZETEC ENGINE	6
21.	WEIGHT	9
22.	SAFETY EQUIPMENT	10
23.	THE MALCOLM GIRLING RULE	10
24.	GRADING & START POSITIONS	10

VIOLATIONS

When referring to the engine, gearbox, differential, mechanical or construction, rules and regulations the principle will always be: Unless permission is specifically granted to make modifications, or any variation, nothing may be done to alter or change in any way the standard Parts.

IT MUST BE CLEARLY UNDERSTOOD THAT THE OVERRIDING PRINCIPLE OF THESE REGULATIONS IS THAT UNLESS IT IS STATED THAT YOU CAN DO IT, YOU SHOULD WORK ON THE PRINCIPLE THAT YOU CANNOT.

Whilst your Promoter will endeavour to inform Competitors of any changes of components or specification they reserve the right to do so at any time during the life of these Regulations.

Cars, Engines and Fuel will be checked on a random basis.

Violations will result in an immediate suspension of all racing facilities and any refusal will also result in an immediate suspension.

All car and engine specifications will be taken from the Technical Service Data book for cars as published by Glass's Guide Service Limited.

Drivers are reminded that scrutineering checks can be carried out at any time, and most certainly at official championships. If parts are suspected of being illegal make sure you leave them with the promotion if you do not agree. If you refuse it will automatically make the parts illegal. **It is the responsibility of the driver to prove to the promotion that the part is legal by the way of written proof of where the part originated. This must be done within seven days, otherwise the part(s) in question will be deemed to be illegal and will result in immediate suspension from racing and referral for disciplinary action.**

1. CARS

Only right hand drive Ford Sierra, BMW any 3 series or Merc C Class 4 cylinder up to 2Litre, are permitted in standard form engine with injection or a zetec transplant with exception of pinto refer to rules, the promotion reserve the right to introduce restrictor plates for the above on standard engines with future observation. Lexus 200 may be used but only with 2Litre zetec transplant. The only engine that can be used for transplant is zetec. Gearboxes are free in standard form, you may use adaptor plate. No competition gearboxes. Only one driver per car and one car per driver is permitted at each meeting.

2. ENGINE

You may use the Ford 2 litre Pinto or the Ford Zetec "Black top" 2 litre engine. Specification for the Zetec engine are detailed. The Ford 2 litre Pinto engine must be in standard form but may have a modified camshaft and may be prepared to the following specifications:

- a) Nominal bore size 90.84mm plus 1.5mm oversize. Standard stroke 76.95mm.
- b) Block and head may be skimmed but the pistons may not protrude above the block. Pistons may not be skimmed or modified in any way. A standard crankshaft must be used.
- c) Engine balancing : CRANKSHAFT – spot machining only; CON RODS – Spot machining only on the counter weight balance pad area at the big and small end. ONE con rod must remain original and untouched. Con rod bolts may be changed but con rods must not be drilled or modified to accept them; PISTONS – Spot machining only and one piston must be original and untouched. All four pistons must have original marking on crown. NOTE: Spot machining means you can either hand grind, drill or machine.
- d) Only standard pistons or standard replacement pistons (i.e. KS Karl Schmidt, Mahle, Hepolite/Well worthy AE) may be used. Any make of piston ring may be used providing the number of rings remains the same as standard and no machining of the pistons or rings other than gapping is required. No forged pistons are allowed. (See 2c for balancing).
- e) Camshafts are free, vernier cam wheels may be used and any single valve spring may be used that fits without any modification to the standard spring tops. Extended ball studs are permitted. Rocker arms are free with the exception of roller rockers. Heavy-duty valve retaining caps are permitted for use. Camshaft centre main bearing caps may be strapped.
- f) Head: You may use any standard 2 litre S.O.H.C. Sierra/Pinto head. No modification is allowed except valve spring seats may be machined. Any single or double valve springs may be used, and the head may be modified to allow them to fit Including Shimming.
- g) Valves must be standard and of standard Ford length. N.B. On Standard Ford Inlet Valves only, where the back of the valve meets the valve seat, there may be a slight lip, this may be ground away at a 30° angle, to a maximum width of 2.5mm. Over size valve stems are allowed, and valve seats may be re-cut. A three angle valve seat may be used to the following specification: Angle 1 – Combustion Chamber 30°, Angle 2 – Valve Seat 45°, Angle 3 – Port 60° - 65°, with valve seat width free. No gas flowing or adding of material to the ports or combustion chamber. Replacement valve guides may be used but must use original position. Bronze valve guides are not permitted, but thin wall bronze inserts may be used.

- h) Flywheel and Clutch: Any standard Pinto engine flywheel may be used which may be lightened. Only the standard type clutch may be used. Flywheels MUST be dowelled to the crank. An approved steel flywheel is available from Turbosport - Contact 01489 406886 or Spedeworth
- i) No competition gaskets allowed. Only Ford, Payen or standard American version may be used.
- j) Standard Motorcraft or Bosch distributors must be used with either points and condenser or electronic ignition.
* See rule 14. The mechanical advance may be altered, and the vacuum advance may be altered or removed.
- k) Engine Mounts: Engine mounting brackets must remain standard, but the mounting may be modified. The engine must occupy its original position. The charging system: Power steering pumps may be removed, fan belts are free but standard pulleys must be used. Blocks may be re-bored to size, sleeved, line bored and surface ground. No other modifications are allowed. Sumps: Standard sumps must be used. Pick up pipes may be modified and sumps may be baffled. No outside alterations may be made.
- l) Oil coolers may be fitted using a sandwich plate between the oil filter and block. Oil coolers must be fitted within the engine compartment. No remote oil filters.
- m) The engine must be fitted with a metal catch tank of 1 litre minimum capacity. It must have a minimum of 2 breather pipes connected to it, one from the rocker box and one from the crankcase. The only modification allowed to the rocker cover is for breathing purposes only.
- n) No turbos, no forced induction of any kind.
- o) The exhaust manifold must be in standard form. The inlet manifold must be standard with the exception of water circulation holes, which may be blanked off.
- p) All engine parts not mentioned above must remain standard.
- q) Water cooling systems may be modified, provided that all modifications are inside the original bonnet outline.
- r) Cables are free.

3. EXHAUST SYSTEM

The standard exhaust system may be retained, Grimley Silencer on rear. A minimum of 2" (50mm) and a maximum of 10" (254mm) section of tail pipe must be fitted to the silencer facing rearwards or down - THIS WILL BE MEASURED FROM THE REAR OF THE BOX (NOT THE PIPE). The front downpipe must remain standard; you may weld a maximum 1½" (38mm) plate in between 2 down tubes to stop them breaking off and you may, at the bottom of the downpipe, fit a fuel mixing sensor the front downpipe can only be modified at the tail end to allow the exhaust to run through the car, by shortening by up to 1". The flange may be removed & the exhaust maybe welded to the downpipe. If exhaust systems pass through the car they must be covered. If a silencer becomes ineffective during racing or practice, the car will be withdrawn from the event. Exhaust must terminate towards the rear of the car and may not terminate through the side of the car.

A standard copy down pipe may be made but must be same length and measurements as a standard ford down pipe.

4. CARBURETTOR & INLET MANIFOLD

Only the standard Weber 32/36 DGV or DGVA carburettor may be used with a maximum of 26mm and a 27mm sized chokes. No polishing or re-profiling is allowed. No modifications to the carburettors body or original design. The interchanging of the carburettor top from other Weber models is not allowed. All gaskets must remain standard and original. A single original spec insulator block must be fitted between carburettor and inlet manifold, with two gaskets; approximate total thickness = 5mm. Main jets, primary and secondary jets, auxiliary venturi and emulsion tubes may be changed but must face downwards towards the butterflies. Accelerator pump jets may be changed but face downwards towards butterflies. Chokes may be modified to open together and replacement spindles may be fitted with standard screws. Cold starting devices may be removed with retaining lugs and subsequent holes blanked off. Air and fuel galleries may not be enlarged or modified, and fuel may enter on either side. Floats may not be modified or weighted, and must control the fuel flow. Needle valves may not be larger than 250, and not enlarged or modified. The power valve must be fitted in the base of the bowl, but may be sealed off, and the diaphragm may be removed. No trumpets are allowed. It is permitted to use a grub screw or similar device to fix the auxiliary venturi to the carburettor body. Top end enrichment devices may be blanked off or modified. A secondary fixing on the fuel inlet feed line is required. The Inlet manifold must be standard & not faced to alter the angle of the manifold to the carburettor. No inlet port matching of the carburettor to the manifold or the manifold to the head. No material may be added or removed from the gas flow area, it must be as standard.

5. GEARBOX & DIFFERENTIALS

All gearboxes must have a conventional type bell housing and the gear change must require a clutch. No competition type gearboxes allowed. Differential ratios are free and may be locked by welding only. No limited slip differentials, no Cosworth, XR4 or 4 x 4 parts to be used. No torque biasing assemblies. Axle and diff must remain the same concept as original. Propshaft is free. Gear sticks are free. The differential must not be moved in any way from its original position, Gearboxes are free, you may use an adaptor plate to fit the gearbox.

6. FRONT SUSPENSION

Positive camber on the offside front wheel is allowed, this can only be achieved by the drilling of the cross member only and the offside bottom arm must remain standard length, the anti-roll bar may be modified to suit. Negative camber on the nearside front wheel is permitted but not adjustable. This may be achieved by re-drilling the cross member

AND lengthening the nearside bottom arm by a maximum of 2", the roll bar may be modified accordingly. Anti-roll bars may be modified to suit. Lengthening must not be achieved with threaded bar. Positive camber on the O/S front wheel is allowed. The springs are free and the car may be lowered. All suspension parts must be located by original mounting points on the chassis and body, with the exception of front bottom arms. Solid bushes are allowed but not competition or Cosworth type. The exception to this is that you may re-drill a maximum of two extra holes (one on each side) in the front cross member bottom arm location. Strut braces may only be fitted on the front struts and may be triangular shape and bolted to the bulkhead only not the roll cage. Top mounting plate may be modified to locate 2¼" springs. Dampers may be up-rated, the Leda leg with non standard spring platform & the Gaz & Shock Tec equivalent may be used, but no metal must be added to them. No adjustable parts. No competition parts.

7. REAR SUSPENSION

The components are to be standard & original in length, but may be upgraded. No adjustable parts, fixed or otherwise are allowed. No other modifications are allowed. Only standard bushes are permitted, no competition parts. Suspension may be lowered. Springs are free. Positive or negative camber may only be achieved by shimming the drive shaft location. No rear Steer. Top spring cups maybe modified to take 2¼" springs.

8. STEERING

The Steering rack must occupy it original position, & manual racks can replace PAS systems. Quick racks can also be used. The steering rack arms may be modified: Nearside rack arm may be lengthened, the Offside may be shortened. The steering column height may be adjusted & reinforced at the top bracket. A quick release steering wheel is recommended.

9. WHEELS AND TYRES

Any steel or alloy wheel can be used to a maximum of 8J, diameter free. Wheel studs are free. No wheel spacers allowed, whether welded to the wheel or not, unless fitted as standard. Tyres are free, 205mm wide or 8^{1/4} wide max.

10. BRAKES

To be original and to work on all wheels. Handbrake is compulsory. No biased braking. No ABS, no 4 x 4 or Cosworth parts allowed. Brake pipes may be allowed to pass through the car. The use of competition brake pads is permitted, however, the use of competition brake pipes is not allowed.

11. BODYWORK

To remain standard including floor pan with removal of inner door panels permitted but any removal of structural stiffeners is not permitted, with the exception of the bonnet and boot stiffeners. No holes are allowed in any panel, other than original. On two door shells, the inner skin may be removed between the B and C posts below the waistline of the car. No armouring whatsoever. All doors must be fixed closed when racing. No spoilers or aerofoils unless fitted as standard to the range of car. Grilles must remain in their original position. Replacement grilles must be made of plastic. Fibreglass grilles are allowed and may include headlamp apertures. Front and rear light apertures may be blanked using a maximum thickness of 2mm aluminium and must not overlap apertures by more than 25mm. Headlamps may be blanked on the front or back of the apertures. All flammable material must be removed. Any replacement dashboards for gauges etc. must be made of aluminium. Wheel arches may be relieved to a maximum of 2" but the original shape must be retained They may be re-welded, but no adding of extra metal and no sharp edges should remain. A metal upright ¾" x ¾" must be welded or bolted into the windscreen aperture, one third of the way along the driver's side. Plastic bumpers must remain in place. In addition Rover 400 Series/Rover 45 or Ford Escort Mk V bumpers may be used as replacements. Additional means of fixing are allowed, but these must not be used as armouring. All fixing bolts must be the coach bolt type with the head of the bolt facing outwards. Standard lifting/towing eyes must be retained. No foam filled panels are allowed. Fabricated doors including the rear quarter are allowed, but must be of professional appearance; the maximum thickness of steel sheet used must be 1mm. There must be no overlapping and should be no thicker than original. Fibre Glass Front/Rear bumpers are permitted and should consist of a maximum of three layers, one of which maybe KEVLAR. The total maximum bumper thickness allowed is 10mm. The circular area of the spare wheel carrier may be removed but must be replaced with a steel plate of equal thickness to the original metal – You may not remove any other sections of the boot floor.

12. ROLL CAGES

The minimum requirement is a four post roll cage with down bars in support of the A & B posts, constructed from mild steel members, minimum size of 32mm x 32mm x 3mm, or 38mm x 38mm x 2.5mm box or tube, all securely welded at all joints as shown and must include the following.

1. A 230 mm square plate, minimum 3mm thick, welded between the base of the uprights and the floor for additional strength.
2. One horizontal bar between A Posts (at dashboard level)
3. One horizontal bar between B posts at approximately mid height and adapted to form support to the seat / seat headrest or a seat hoop.

4. Two “chicken” bars in the drivers door aperture and two in the passenger door aperture. Chicken bars to fit between A & B post support down bars and no further. Bars that lay on the sills will not be classed as chicken bars.
5. Two down bars, one each side from the roll cage top, to either, the rear suspension turret (5) or (5A) into the boot well, terminating 100mm short of the back panel.
The following members may be added (to the same material specification as the roll cage) :
6. Two bars, one each side, from the B post down bar base, rearward to the suspension turret.

ROLL CAGE DIAGRAMS

MINIMUM SPECIFICATION ROLL CAGE

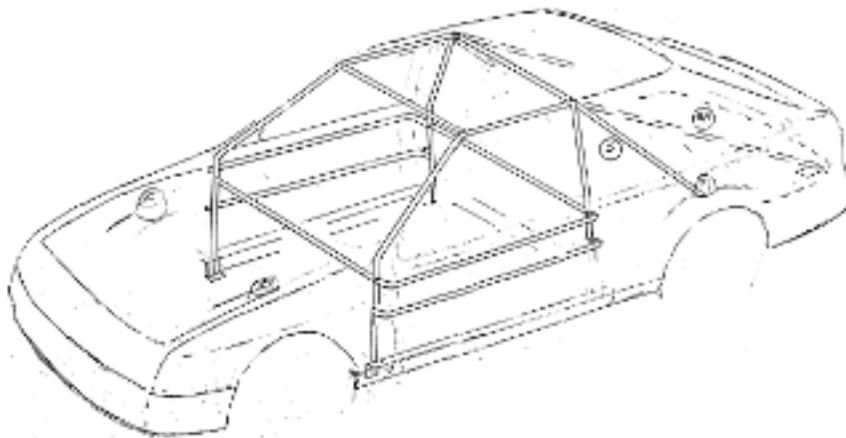

MAXIMUM SPECIFICATION ROLL CAGE

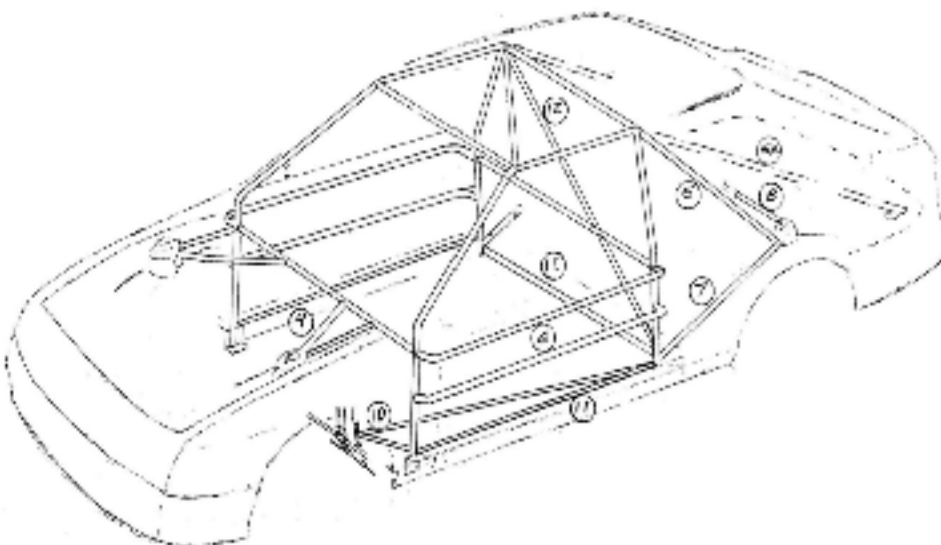

7. A cross bar fitted across the rear suspension turrets, this may be cranked and welded to the floor panel in a central location.
8. Members may be positioned from the roll cage, forward through the bulkhead and connected to the front suspension turrets. Members must be within the engine bay aperture and horizontal (within practical limits)
9. Additional bars in passenger side to support front roll bar, rear mounting area (in the footwell). Bars must be positioned low down such that access to the driver is not limited.
10. One horizontal bar each side between A & B post support down bars at sill height and between B posts (to protect legs/feet in a side impact situation).
11. One diagonal member between either B post support uprights or rearward members described in (5)

Further Notes

No suspension components may be fixed directly to roll cage / support members.

All members must be positioned within the body lines and fitted as supports/protection NOT armouring.

No other members must be added as the list above describes the full limit of roll cage construction that is allowed.

Please refer to the roll cage diagrams which illustrate the minimum required and the maximum allowed.

13. SCREEN

All glass must be removed. Front screen must have a central bar of 19mm x 19mm or 3/4" x 3/4" SHS welded in place. An interior mirror must be fitted. A drivers door mirror must be fitted, mounted in such a position that it does not project further out than the body. (Must not be able to get knocked off whilst in racing traffic)

14. STOP LIGHTS

Either two stop/brake lights or one single stop/brake strip-light must be fitted facing rearwards. If two lights, they must be a minimum of 30 inches (762 mm) apart. Lamp(s) must be operated by the standard stop light switch as fitted to the particular model of car. No other switches or modifications to switches to be made. Bulbs to be of 21 watt intensity. For round type lamps: minimum diameter 3" (76mm), maximum diameter 5" (127mm). For square/rectangular type lamps: minimum 3" (76mm) square, maximum 5" (127mm) square. For strip type lamps, minimum of 8" (203mm), maximum of 16" (406mm) width and should be fitted securely to allow a clear view from the rear. All bulbs must be working. All brake lights must be Red.

15. SEATS

You must have a Competition type Driving Seat with a head restraint.

The seat should occupy its original position where possible and be suitably supported at shoulder height and on both of the sides and back, with a suitable framework or seat stiffener's.

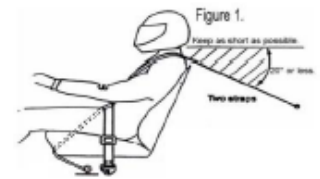

16. BATTERIES & ELECTRICAL

May be brought inside the car, but the floor must not be cut to accommodate the battery. They must be firmly fixed and covered with a material which will not rot due to acid contamination. Contact between the safety harness and batteries must not be possible. Batteries must be a minimum of 6" (152mm) from fuel tank. An electrical cut off switch must be fitted to the R/N/S corner of the car. If Lumination is used they must be of the following part nos: Ford: Bosch fitting kit FK221 power module PMA50, Motorcraft FK9 PMA50. A 24 volt starter system is permitted.

17. NUMBERS

The driver's racing number must appear on the doors of the car. They should be preferably in large American style numbers on a contrasting background. The bigger the better. You should also paint your number in black on white or white on black in the rear corner of your roof to assist with lap scoring at tracks with race controls that are located in a high position. A 'Sun Visor' made of metal and having a depth of at least 6" must be fitted to the top of the windscreen aperture when no laminated glass or perspex is fitted. The drivers name only must appear across the sun visor position. All signwriting must have a professional appearance.

Scrutineers will instruct drivers to change their numbers if lap scorers find it difficult to read them. The whole of the roof of the car (with the exception of number triangle) must be painted in the drivers current grade colour.

Fin numbers are optional must be Black 9" high in 1 1/2" strokes minimum. The fin plate must be black numbers with a white background with the bottom fitted on or above the roof gutter but be no higher than 12" in total from the roof. If a driver chooses not to run a fin plate then the number must still appear on the roof. All numbers must be of professional appearance.

If you win a race at a meeting; you will start the remaining races from the rear of your grade. Should you win another race at the same meeting – you will be automatically upgraded.

18 FUEL SYSTEM

Fuel tanks must be metal or FIA approved with a maximum capacity of 4 gallons or less are permitted. These must be fitted rear of the driver but in front of the rear axle centre line, i.e. they are no longer allowed to be fitted in the boot area. They **MUST NOT BE FITTED BELOW THE CHASSIS RAILS** of the car, and the floor must not be cut in any way to accept the tank. All tank filler caps must be of a secure leak proof metal or screw fitting. Petrol pipes must be of metal or metal covered and have a shut off tap within easy reach of the driver. All tanks must be fitted with a breather system which prevents spillage if a car is inverted. The fuel tank must be a minimum of 6" (152mm) from the battery. All petrol pick up pipes must draw through a stand pipe from the top of the fuel tank. Four 2" holes must be drilled at the lowest point under tanks to allow spilled petrol to drain. A firewall between fuel tank including filler cap/pump and driver must be fitted. Fuel regulators may be used.

19 FUEL

Standard road fuel only.

20. ZETEC ENGINE

The only permitted Zetec Black top engine is the Ford 1988cc, 16 Valve engine in its 136PS form (codes NGB ED-DA-G EBBC EBBB EDBA EDBB) with nominal bore 84.80mm and stroke 88.00mm. Or new standard uncoded Ford replacement complete engine. Production tolerances are permitted providing the total swept volume does not exceed 1989cc.

Specifications of the Zetec Engine are further detailed below as follows :

20a : ENGINE GENERAL

- a) Engines will be mounted upright, and aligned fore and aft in the chassis.
- b) The addition of any material be it metal, plastic, or composite etc. by any means be it welding, bonding, encapsulation or encasement to any component is prohibited. However, specific repair of the mounting points of the cylinder block to the transmission or chassis is allowed, whilst other casting repairs may be allowed with prior written approval of Spedeworth.
- c) The use of non-standard replacement fasteners, nuts, bolts, screws, studs and washers which are not connected with, or which do not support, any moving parts of the engine or its compulsorily retained accessories is permitted.
- d) Freedom granted to any fastener does not allow for freedom to move items relative to each other. For components that are granted the freedom for the fitment of a key or dowel, then material may be removed to allow the fitting of the key or dowel. Only one hole or keyway per component is allowed.
- e) The use of thread locking compounds is permitted.
- f) Gaskets are free however, no competition gaskets are permitted.
- g) Any process of cleaning may be used on any component providing the surface finish, which must remain standard, is not affected.
- h) The expression 'Standard', 'Standard production', or similar expression is deemed to imply that the part has been manufactured by Ford, or a Ford Motor Company Ltd. authorised sub contractor, for specific use on a specific model of the engine.
- i) Any machining marks on cast components resulting from manufacturing procedures will not cause disqualification.
- j) Only machining and component preparation carried out by Ford Motor Company Ltd., or by a Ford Motor Company Ltd. authorised sub-contractor is allowed unless otherwise specified.
- k) Any production debarring or imperfection removal during initial manufacture may not be modified or extended. The scrutineer's decision will be final if a dispute arises regarding the amount of tool, or other marks that are evident in any particular component.
- l) The exterior surfaces only (of the complete engine assembly) of ferrous parts may be protected by paint or similar means.
- m) No internal component or surface may be coated by any protective finish.
- n) No aluminium components may be protected.
- o) The only exception to this is the exterior of the Cam cover/Rocker Cover.
- p) This paragraph confirms previous and future statements that no rework may be carried out on any component unless specifically authorised by Spedeworth. The engine and associated parts must remain exactly as produced by the Ford Motor Company unless expressly detailed in these regulations. If the regulation allows a change, then that authorization would allow the change to be carried out. However any statement defining minimum weight or dimensions does not grant permission for rework to obtain these minimum values, unless carried out in accordance with these regulations. Only Ford standard parts (Parts manufactured by Ford or a Ford Motor Company authorised sub contractor) specifically for the 2 Litre "Blacktop" version of the engine can be used in these formulas.

- q) No treatment that alters in any way the surface finish, hardness, or other property of the original production component is allowed. The only exception to this is any deposit derived from the lubrication and combustion processes naturally occurring during the running of the engine.
- r) Spedeworth reserve the right to prohibit the use of specific components introduced as production changes, if in the opinion of Spedeworth, they are deemed to have a performance advantage. If in doubt, contact Spedeworth.
- s) Engine/transmission mounts attaching to standard Ford components must retain the standard dimensions of the boss or other attachment point without modification. All motor codes, numbers and build specs etc must be visible and un touched.

20b : CYLINDER BLOCK

- It is not permitted, as means of repair, to replace damaged cylinder bores with cylinder liners.
- No machining of the cylinder block is permitted except honing/glaze busting of cylinder bores.
- The crankcase breather may be modified, including removal, as long as no air and/or oil escape from this area other than through pipe-work to the catch tank.
- Pistons must not protrude above block deck face at any point.
- Standard oil dipstick tube and dipstick must be fitted.
- It is not permitted to remove or modify the four standard oil spray jets.

20c : OIL PUMP

- It is not permitted to modify the standard Ford oil pump/front cover in any way.

20d : CYLINDER HEAD (INCLUDING VALVES AND VALVE GEAR)

- It is not permitted to replace valve guides and valve seats inserts.
- No work that removes, adds, replaces, or transfers material is allowed on the cylinder head with the following exceptions.
 - Simple cleaning which does not alter in any way the shape of the component.
 - Minimal material removal from the head face to correct combustion chamber volume and/or reclaim head flatness.
- No internal rework of any combustion chamber is permitted
- The cam cover assembly cannot be modified or replaced.
- The oil filler cap shall be sealed by spring/lock wire or similar.
- All valve train components must remain standard.
- Valves must remain standard Ford supplied items, no re-profiling or polishing is permitted. The original 45° (90° included) seat angle must be maintained.
- Standard valve stem seals must be retained.

20e : CAMSHAFTS AND PULLEYS

- The only permitted camshafts are the standard production camshafts as per picture below.
- The camshafts must remain entirely unmodified. It must be fully manufactured and ground by the Ford Motor Company. It is prohibited to grind from blanks, re-grind or re-profile. Only the production surface finish is permitted. Shot peening, shot blasting, surface treatments or polishing are prohibited.
- Exhaust and inlet camshafts must not be interchanged.
- The only permitted camshaft drive pulleys are the standard Ford items.
- The cam drive pulleys may be keyed to the camshaft by dowel only.
- The sprung loaded cambelt tensioner may be locked or replaced with fixed item.

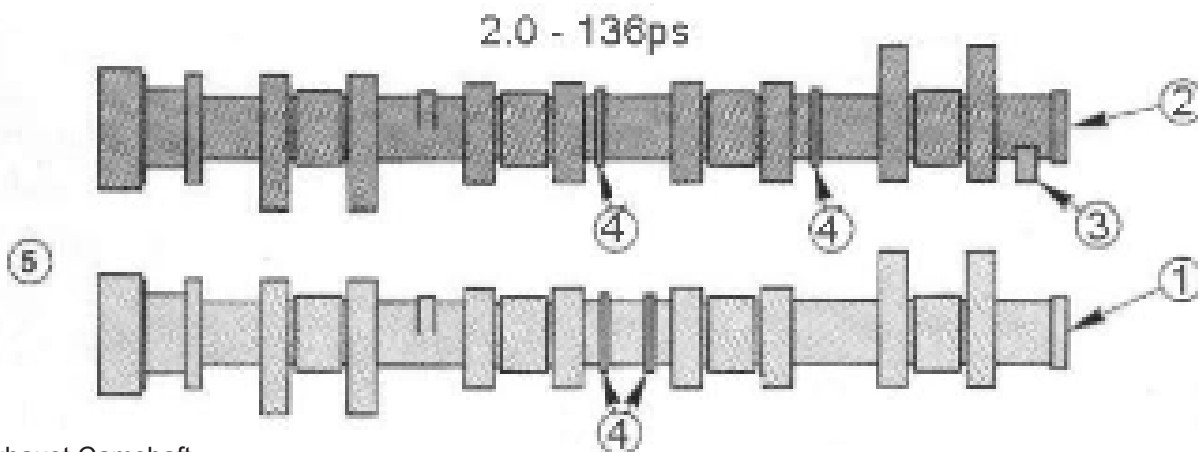

- 1. Exhaust Camshaft
- 2. Inlet Campshaft
- 3. Cam Position Reference - Inlet Camshaft
- 4. Identification Rings
- 5. Driving end (pulley end)

20f : CONNECTING RODS

- Connecting rods must be standard.
- Machining/grinding is not permitted to remove metal from the connecting rod or cap.
- Polishing is prohibited.
- Connecting rod bolts are free subject to them remaining in ferrous material, the con rod may not be modified to fit bolts and the minimum weights respected.

20f : PISTONS

- Pistons must be standard production pistons unmodified in any way.
- All three piston rings must be fitted as intended, piston rings must be standard production items or replacement items to Ford Motor Co. dimensions.

20g : CRANKSHAFT

- A standard crankshaft must be used.
- No balancing is permitted.
- Polishing other than the 9 bearing surfaces is prohibited.
- Crankshaft journals must remain within Ford positional tolerances if a repair re-grind is carried out.
- Crankshaft pulley and damper must be retained and unmodified.
- Additional drives to water pump may use this pulley, or extra pulleys mounted in front of the crankshaft damper.
- It is not permitted to alter the number of bearings or fit bearings of less than standard production width.
- The crank journals may be re-ground for reclaim.
- Standard oversize and undersize bearings are permitted.
- A marker must be fitted which accurately aligns the crankshaft to the cylinder block at No.1 piston TDC. This marker must be visible and fully accessible to the scrutineer's without removing any component other than external bonnet panels, and without removing the engine from the car.

20h : FLYWHEEL AND CLUTCH

- Standard fly wheels only.
- Flywheel bolts are free subject to them remaining in ferrous material.
- No modifications to either crankshaft or flywheel in order to fit is permitted.
- Clutch to be standard Ford Pinto based 8.5"
- No competition items.

20i ENGINE COVERS

- The cam belt covers cannot be modified or deleted.

20j SUMP AND PICK UP PIPE

- Oil sump and oil pick up pipe are free.

20k OIL FILTER

- Oil filters are free but must have a secondary fixing.

20l OIL COOLERS

- No oil cooler is permitted.

20m COOLING SYSTEM

- A water based liquid cooling system is mandatory.
- The standard production water pump and housing must be retained, although drive to the pump, its rotational speed and direction may be changed.
- The radiator and associated pipes are free.
- No other pump may be used to circulate or assist circulation of the coolant liquid.
- Thermostat housing is free.

20n : ENGINE IGNITION CONTROL UNIT (ECU) AND ELECTRICAL

- The only means of ignition will be by use of Ford crankshaft speed sensor fitted to the standard manual sensor housing and Ford based ignition coil.
- No other sensors engine or chassis permitted.
- The mandatory engine ignition control unit (ecu) and wiring loom supplied by Spedeworth will be registered to driver and electronically sealed. Neither can be modified in any way.
- The engine ignition control unit (ecu) and/or any other ignition components may be exchanged, or electronically interrogated at any time (including the time allocated for practice or testing) upon the request of a designated official from Spedeworth.
- It is prohibited to use any other method or component to trigger, distribute or time the ignition.
- The coil unit may be re-positioned

- The HT leads to the sparking plugs are free.
- Sparking plugs are free, provided they fit the engine without any modification to the cylinder head or the sparking plug and that the sparking plugs place the spark gap in the same position as the production sparking plug within the combustion chamber.
- The ECU diagnostic connector must be positioned in an accessible position, allowing the scrutineer free access to it at all times.

20o : INLET MANIFOLD

- Mandatory inlet manifold supplied by Spedeworth may not be modified internally.
- Standard manifold to head casting gasket or silicone based sealer may be used to seal face to cylinder head only.
- At any point in time Spedeworth can introduce the fitment of a restrictor plate fitted between manifold and carburettor mounting plate of any given size if it is deemed suitable to reduce the output of any engine at any time before during or after any practice, testing or racing.

20p : CARBURETTOR

- Only the standard Weber 32/36 DGV/A carburettor may be used with a maximum sized chokes of 26mm & 27mm.
- No polishing or re-profiling is allowed.
- No modification to the carburettor body or original design. The interchanging of the carburettor top from other Weber models is not allowed but float bowl vent may be modified.
- Gaskets must be original or replicas of original (i.e. no modified gaskets).
- A single original specification adapter/insulator block must be fitted between carburettor and inlet manifold, with two gaskets approximate total thickness 5mm I.E. as supplied with Gasket set.
- Main jets, primary and secondary jets, auxiliary venturi, and emulsion tubes may be replaced with a different size of the same part.
- Accelerator pump jets may be changed, but face downwards towards butterflies.
- Butterflies may be modified to open together, replacement spindles may be fitted with standard screws. Cold starting devices may be removed, with retaining lugs and subsequent holes blanked off.
- Air and fuel galleries may not be enlarged or modified; fuel may enter needle valve/float chamber from either side. Floats may not be modified or weighted, and must control the fuel flow.
- Needle valves may not be larger than 250, and not enlarged or modified.
- The power valve must be fitted in the base of the fuel bowl, but may be sealed off, and the diaphragm may be removed.
- No trumpets are allowed. The calibrated brass bush which controls the high speed enrichment, fitted on the secondary venturi side of the carburettor between the top and base of the carburettor, may be sealed off or enlarged, but must be fitted.
- A secondary fixing on the fuel feed-line is required. It is permitted to use a grub screw, or similar device, to fix the auxiliary venturi to the carburettor body.

20q : EXHAUST

The exhaust manifold to be used must be the Ford Focus small four branch manifold which must remain standard, you can weld to this, making your own exhaust. The Grimley silencer must be used.

21. WEIGHT

Warning : Cars can be weighed at any time before, during or after a meeting, without driver. They must always achieve the minimum weight; the adding of fuel or any other liquids is not allowed to achieve this minimum weight. The minimum car weight is 845Kg. The use of ballast to achieve this weight must be steel plate bolted to the floor. The internal plating must be of equal proportions on both sides and front to rear of the car both in construction and gauge. i.e. If a 10Kg weight is fitted in the front offside foot well, a 10Kg weight must also be fitted in the nearside foot well. Bolts of the same size and material must be used to fit the plates and the bolts must be welded. Underweight Vehicle Bans Car Underweight by: Banned From Racing For:

0.001kg – 1.0kg	1 month
1.001kg – 2.0kg	2 months
2.001kg – 3.0kg	3 months
3.001kg & over	6 months

22. SAFETY EQUIPMENT

- Helmets must be of a minimum standard as directed by British Oval Racing Safety Executive (B.O.R.S.E). These are FIA8860-2004, FIA8860-2010, sSnell SA2010, Snell SA2015, SFI Foundation 31.1A, SFI Foundation 31.2A. The E2205 European standard helmet may be used in Fibreglass, Carbon or Tri-Composite form only i.e. NO POLYCARBONATE helmets are allowed. It is important that the helmet fits the driver correctly. Shatterproof goggles/visors must be worn although tinted visors are not advisable. Your helmet must display the current ORCi (ORC15) sticker.
- Neck braces are recommended.
- Fireproof balaclavas are MANDATORY and must be marked appropriately.
- Fire retardant gloves are MANDATORY and must be marked appropriately. Drivers must wear bright coloured racing overall type clothing of flame retardant Proban or a high specification material and this must be maintained in a clean and tidy condition in view of the public. N.B. If wet weather clothing is used this must be worn IN ADDITION TO and NOT INSTEAD OF the regulation flame retardant overall type of clothing described above.
- A quick release cloth window net must be fitted to the driver's door window aperture. The netting should have holes not larger than 7.5cm or 3" wide. It should come down level with the steering wheel, and should be flexible and easily removable separate to the movement of the door.
- A 1Kg Dry Powder Gauge Fire Extinguisher is highly recommended and if fitted, this should be in a tube with a spring top and should be within easy reach of the driver. Old type BCF (green) type extinguishers are not allowed. All tow vehicles, must carry a minimum of a 2kg fire extinguisher dry powder or gas, which must be within easy reach of the driver and mechanics at all times, especially when refueling.
- A minimum of 3" (75mm) wide safety belts (1.75" (40mm) sub-strap) are mandatory. This must be a full five point buckle release harness (including NASCAR type) with sub-strap and must be fitted and bolted to the floor and/ or the roll cage. Shoulder belts with a sternum protection latch are highly recommended. The sub-strap must be used at all times and all belts must connect to the quick release buckle. In the case of NASCAR lever latch buckles it is advisable to fit a secondary means of detent to prevent overall sleeves accidentally unhooking buckles during racing. A small section of Tubegrip elasticated bandage slid over the hooked buckle serves this purpose. Special attention must be paid to the condition of seat belts and fixings once fitted. An extra bar is to be fitted to roll cage behind drivers seat approx 4" below shoulder height of driver. Your seat belts may be fixed to this bar. The bar is to be of roll cage material specification.

23. MALCOLM GIRLING RULE

The Malcom Girling Rule may only be used on championship races which covert a roof grade e.g. World Championship. This is when a car has deliberately been taken out by breaking the rules of racing within the last 3 laps of the race e.g. a car coming off the infield to stop the leader.

If the Steward Of The Meeting decides that the Malcolm Girling has come into effect the result shall go back to when the offence occurred and the leader of the race at that point will become the winner. The Malcolm Girling rule only applies to the driver leading the race.

24. GRADING & START POSITIONS

All cars must have ns front corner of their roof painted (or a minimum of a 609mm (24") wide stripe), with a 51mm (2") wide stripe either side - in contrasting colours - from the front to the rear, in their roof grade colours. The grading strip must not have any sign-writing on it. If you win a race at a meeting; you will start the remaining races from the rear of your grade. Should you win another race at the same meeting – you will be automatically upgraded.

Multi-Champions will start next to the World Champion.

When signing in you will be issued with a grid which shows your starting position for your races, unless you are instructed differently by a race official or it is a championship event i.e Reverse grid format. Drivers are reminded that it is your responsibility to line up in the correct position on the grid this includes leaving gaps if certain cars are absent. If spotted starting in the wrong grid position before the initial green flag you will be penalized to the back of the grid. If it is brought to the steward of the meetings attention after the initial green flag you will be excluded from the result. This is subject to change depending on the promotion, drivers should confirm with the steward of the meeting beforehand which race format is being used.

Please note that all of the above rules are subject to change in respect of Health & Safety requirements.

Drivers and teams are reminded that a secondary means of supporting a vehicle must be used when working underneath a car that has been jacked up (i.e. axle stands).

The following parts are available from Spedeworth Fabrications
Inlet Manifold, Ignition pack and wiring loom